

Introduction:

High quality flat turbo Aluminium base diamond grinding cup wheel for stone grinding wheels are designed for fast rough dry or water-cooling grinding and sharpening of marble and granite surfaces, corners edges and angles, comes in aluminum base providing light weight and fast cooling effect by high conductivity.

Aluminium cup wheels, This aluminium base diamond stone grinding cup wheel are mainly used for stone grinding on the manual grinding machines, the thread could be in M14, 5/8-11 or 22.23mm. It's the most cost-effective diamond grinding cup wheel for your stone.

Grits 30# diamond grits provide high efficiency and longer working life;

Grits 120# diamond grits provide great finishing and much longer working life.

Applied Machine: Most floor grinders plate

Application: For Granite, marble, concrete, block, etc.

Usage: These grinding wheels are great for any type of concrete construction work, they can also be used for aggressive stock removal with granite, marble, limestone, Terrazzo. Use wet or dry.

Feature:

1. Resin filled help to get better finishing, less scratch;
2. Aluminum base provide light weight and lower noise;
2. Hot-Pressed segments, efficient and smooth grinding;
3. Characterized by high working efficiency and using easily;
4. The diamond cup wheels include single row and double row;
5. It attaches to hand held grinders and floor polishing machine;
6. Applicable for fast grinding, rough deburring and smooth shaping and finishing of stones, masonry materials.

Specification:

High quality flat turbo Aluminium base diamond grinding cup wheel for stone

Diameter	Connection	Segment Size	Grits
4inch/100mm	Bore 22.23mm(7/8inch) with reducer washer 16mm	7mm thickness	30#
4inch/100mm	Bore 22.23mm(7/8inch) with reducer washer 16mm	7mm thickness	120#
4inch/100mm	M14 Thread	7mm thickness	30#
4inch/100mm	M14 Thread	7mm thickness	120#

Other diameter or specifications can be customized according to buyer's requirements.

Pictures:

High quality flat turbo Aluminium base diamond grinding cup wheel for stone

boreway®



Boreway Machinery Co., Ltd.
www.diamondtools.top
www.boreway.com

M14 Aluminum Based Diamond Grinding Wheel

Higher efficient

Lower noise

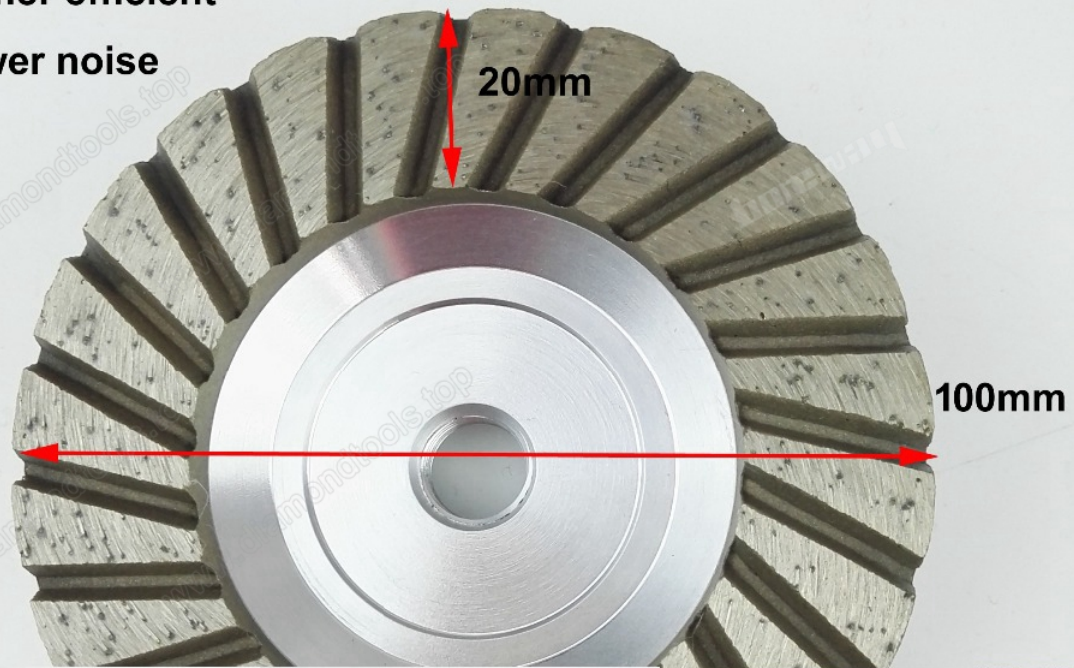

M14 Thread



7mm Thickness



**#30
Coarse**

**#120
Fine**





30# High quality flat turbo Aluminium base diamond grinding cup wheel for stone

boreway®



Boreway Machinery Co., Ltd.
www.diamondtools.top
www.boreway.com



Boreway Machinery Co., Ltd.
www.diamondtools.top
www.boreway.com

120# High quality flat turbo Aluminium base diamond grinding cup wheel for stone

boreway®



Boreway Machinery Co., Ltd.
www.diamondtools.top
www.boreway.com

boreway®



Boreway Machinery Co., Ltd.
www.diamondtools.top
www.boreway.com

boreway®



Boreway Machinery Co., Ltd.
www.diamondtools.top
www.boreway.com



Boreway Machinery Co., Ltd.
www.diamondtools.top
www.boreway.com

More Related Turbo Grinding Wheel, Pls click here: [Diamond Grinding Cup Wheel](#)

Packing & Delivery:

1. Tools packing in carton cases;
2. When tools are in large quantities, they are packing in wooden cases.

-DELIVERY-

Less than 45kg,generally delivery by express(Door to Door).



By Air / Sea for batch goods, Airport / Port receiving.

BY AIR



BY SEA



Contact Us:

Fujian Nanan Boreway Machinery Co.,Ltd.

Address: Huahui Center 605, Shuitou Town,Quanzhou, Fujian, China.

Post Code: 362342

Tel.: 0086-595-86990206

Fax: 0086-595-86990220

Contact: Ally Huang

Mobile/WhatsApp: 0086-13559599186

Wechat: boreway05

Skype: boreway05

Facebook: 13559599186

E-mail: boreway05@boreway.net