

## Product Description

[Continuous Rim Diamond Cutting Blades For Suppliers](#) is a particularly stable and mature diamond saw blade,

especially suitable for cutting ceramics, porcelain, vitrified tiles, granite, stoneware, hard tiles and other stone.

continuous rim diamond cutting blades can reduce cutting friction a lot, improve slab flatness, save energy.

## Feature:

Cutting method: Wet cutting, Dry cutting.

Fast cutting & long life, Stable performance.

High quality industrial diamond grain was used in segment

Fast cutting and low waste Hard material, granite marble tile ceramic brick etc.,

Hot-pressed sintered blades provide long working life which can cutting multi materials

Circular Porcelain Concrete Cutting Blade can reduce cutting friction a lot, improve slab flatness, save energy.

([Diamond Circle Saw Blade welding machine In China](#))

## Product Specification:

**The followings are the normal specifications of our continuous rim diamond cutting blades :**

Diameter	Thickness	Inner Hole	Segment Height
6 Inch, 150mm	2.6mm	22.23mm	8mm

**More normal specification of diamond saw blade suppliers:**

Diameter	Bore	Segment	Segments	Segment
----------	------	---------	----------	---------

Inch/mm		Size (mm)	Width (mm)	Thickness (mm)	Height (mm)
4	105	16/20 22.23 25.4 50	35	1.8	8/10/12
4.3	110		32.3	1.8	8/10/12
4.5	115		38.5	1.8	8/10/12
5	125		37.5	2.0	8/10/12
6	150		33.5	2.2	8/10/12
7	180		35	2.4	8/10/12
8	200		39.2	2.4	8/10/12
9	230		34.4	2.6	8/10/12

The above specifications are for reference, other specifications can be ordered by customers. ([Best Price Diamond Saw Blade Manufacturer](#))

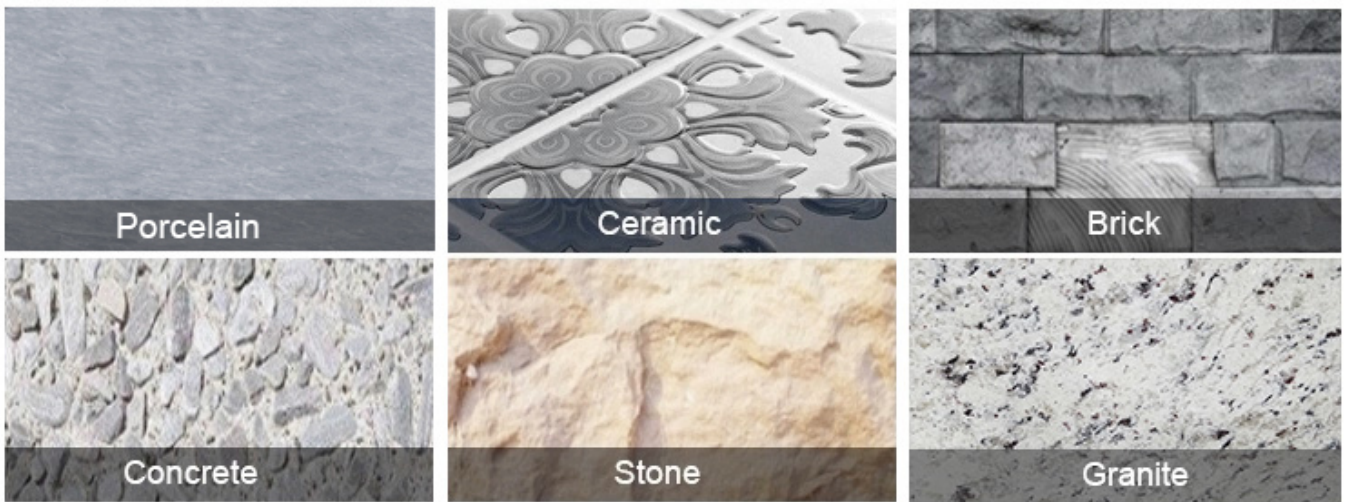

Electric circular saw



Angle Grinder



Multi-function cutting machine

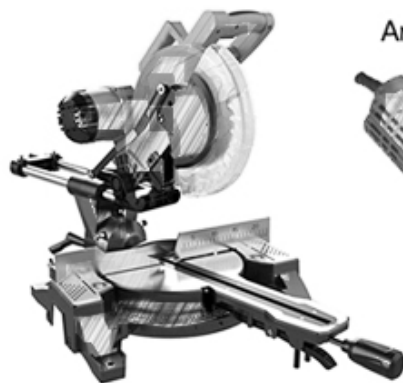

Road cutting machine



**Product show**

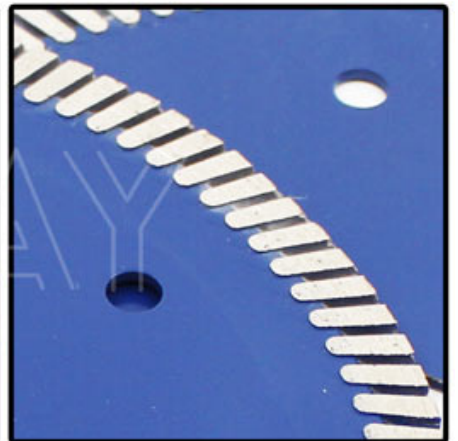
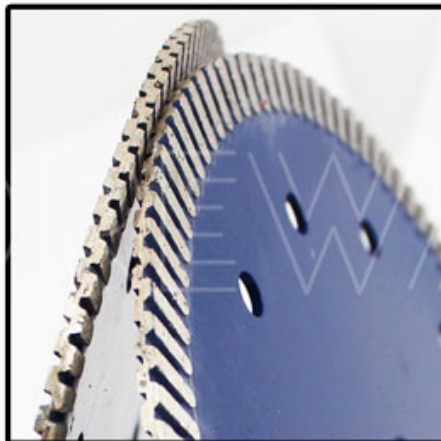
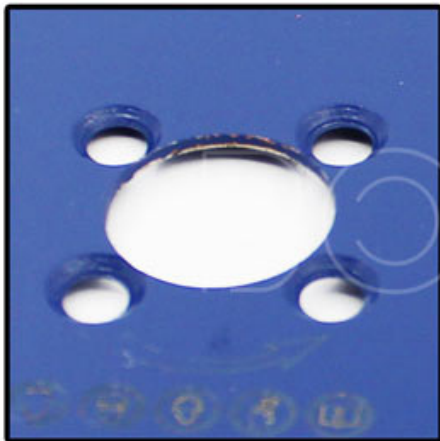

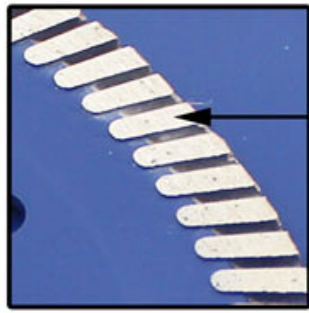

Fine Tooth Turbo Segment

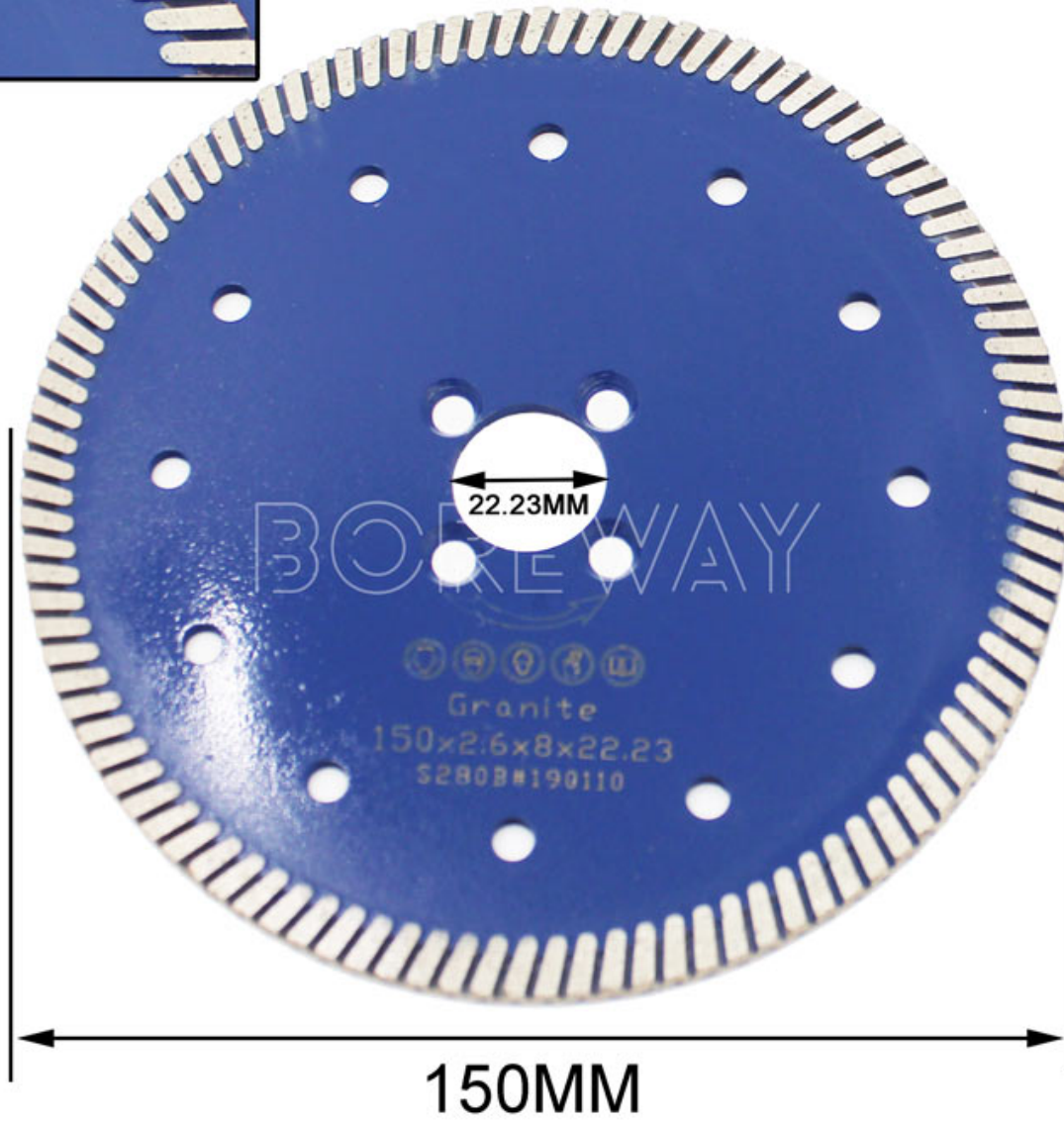

150MM  
Diamond Saw Blade For Granite





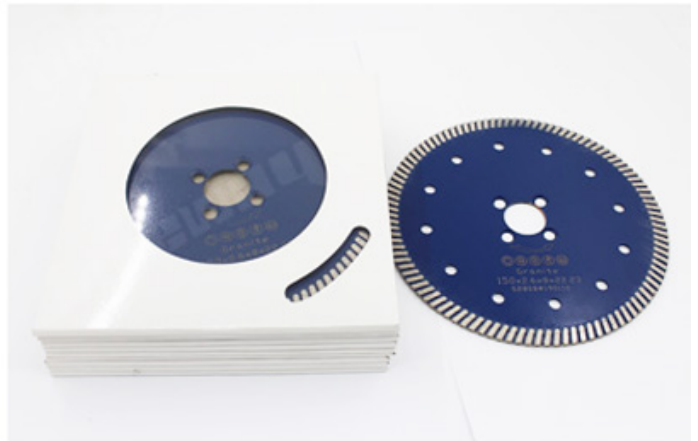
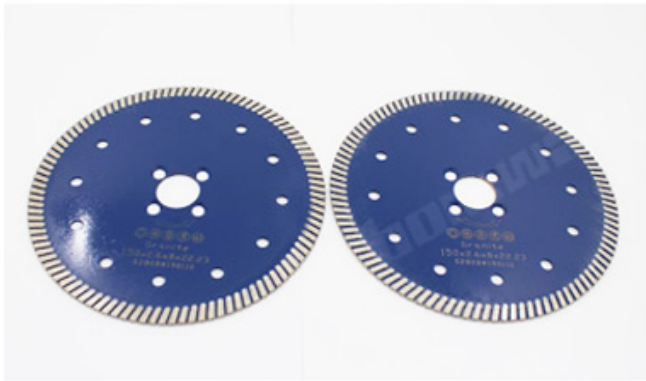

### Application:

Continuous rim diamond cutting blades use for manual, pneumatic cutting machine, angle grinder.

### Attention when use:

1. Before saw blade installed, pollutions adhering between saw blade and flange shall be removed, when installing saw blade, the marked direction shall be kept consistent with the rotating direction of electric tools, and flange shall be fastened by spanner attached to electric tools.
2. Do not use any saw blade that has been deformed for being pressed or crashed.
3. When operating, operator must wear safety helmet, safety footwear and goggles, protective glove, additionally, if necessary operator must use earplug, mask and so on
4. Electric tools shall have protective cover.

### Kindly Noted, when place order please inform the following:

1. Blade Width (2.8-9.5mm)
2. Whether With Flange Hole (Yes/No)
3. Length Of Diamond Segment (40/24mm)

4.Segment Height (8/10/12/13/15/20/30mm)

5.Saw Blade Use (Dry Cutting/Wet Cutting/Grinding)

6.What Are The Diameters Of Saw Blades (105-250mm and 250-3500mm)

7.Production Process (Sintering, Welding, Electroplating, Brazing, Inserting)

8.Saw Blade Inner Hole (16/20, 22.23, 25.4, 50, 50/60, 60/80, 90/100, 100/120mm)

9.Saw Blade Type (Segment Tooth, Continuous, Gang Saw, Band Saw, Wire Saw, Combined Saw, Arc Film, Slotted Saw Blade)

10.Saw blade type □Segmented ,Continuous Rim,Segmented Turbo,T-shaped with Protecting Teeth, Segmented Turbo with Protecting Teeth, etc.

11.Cutting Tool Type: Circular Saw Blade, Gang Saw, Band Saw, Wire Saw, Multi-Blades, Tuck Point Blades, Etc.

12.Cutting Machine (Manual, Pneumatic Cutting Machine, Angle Grinder, Bridge Cutting Machine, Manual Cutting Machine, Desktop Cutting Machine, Infrared Cutting Machine, Marble Machine, Road Carving Machine)

13.Cutting Objects (Granite, Marble, Quartz Stone, Glass, Jade, Terrazzo, Concrete, Ceramics, Ceramic Tiles, Artificial Stone, Sandstone, Limestone, Microcrystalline Stone, Basalt And Other Materials)

**Factory Show**





## FAQ

### **1.How could we know the quality, if we want to order your products?**

Please just test them with a very small order, then you will know the quality. At present,so many people in the world to use Chinese products, because of the high quality and most competitive prices. We are professional manufacturer in supplying diamond tools for more than 8 years. Anyway, confirming our products quality, a small trial order for testing will be necessary.

### **2.Can you offer free samples?**

We don't offer free samples, according to our many years experience, we think people get the samples by paying, they will cherish and appreciate more what they get. But we are willing to give our potential customers a special discount which they are used to do a testing.



It is very important to give us feedback, we appreciate it.

### 3.Does your company accept custom-made?

Surely, we accept it. Including different color, grit etc. We also can mark your own logo and brand on the pad. Any new products you want us to produce for you, just send us your drawing or sample, we will produce the same one. We will not sell this kind of products to other customers only if we get your permission.

### Logistics:

Sample order ship by DHL, UPS, FedEx, TNT, EMS etc

For mass order delivery, can be optional with terms of Exwork, FOB, CNF, CIF by air or by sea based on the buyer's forwarder or ours



### Contact Us:

Fujian Nanan **boreway**® Machinery Co.,Ltd.

 No.605 Huahui Center, Shuitou Town 362342 Quanzhou, Fujian, China

 **TEL:** (+86)595-86990206 /  **Fax:** (+86)595-86990220

 **Mobile/WhatsApp/Wechat:** (+ 86) 18650679939

 **E-mail:** [boreway@boreway.com](mailto:boreway@boreway.com)

 **Lyon Chang**