

□□□	45Mn□
□□□□□	□□□□
□□□□□	□□□□□
□□□	□□□□□□□□
□□□□□	□□□□□□□□□□
□□□	□□□□□□□□
□□□	4□□□D100MM□□4.5□□□D115mm□□5□□□D150mm□□7□□ □D180MM□

□□□□□□□□□□□□□□□□□□□□
□□□□□□□□□□□□

□□□□□

□□□□□



4 Inch

4.5 Inch

5 Inch



SINGLE ROW GRINDING CUP WHEEL



Fast Grinding
5MM workable thickness
3MM Strong Core Steel

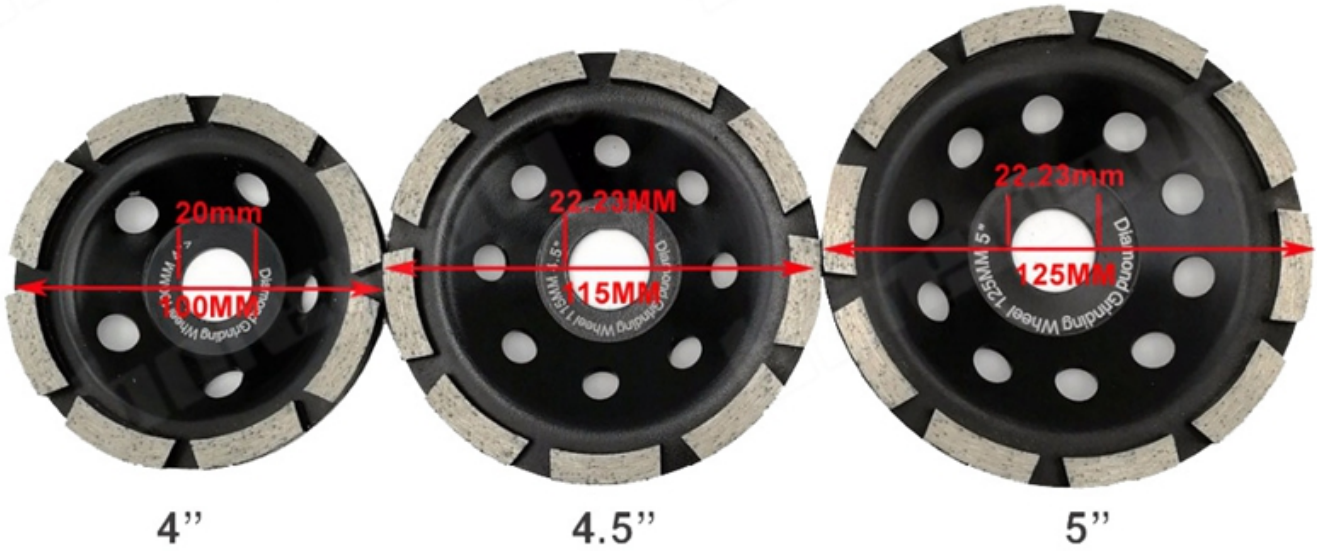







Boreway Machinery Co.,Ltd
www.diamondtools.top
www.boreway.net

4



Boreway Machinery Co.,Ltd
www.diamondtools.top
www.boreway.net

4.5

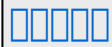

□□□□□□

1. □□□□□□□□□□□□□□□□
2. □□□□□□□□□□□□□□□□
3. OEM □□□□□□□□□□□□□□□□
4. □□□□□□□□□□□□□□□□□□□□
5. □□□□□□□□□□□□□□□□□□□□

□□□□

1. □□□□□□□□
2. □□□□□□□□
3. □□□□□□□□□□

□□□□□

Fujian Nanan *boreway*® Machinery Co.,Ltd.



□□□□□□□□□□□□□□□□605□362342



□□□ □+86□595-86990206 /  □□□ □+86□595-86990220



□□/ **WhatsApp** /□□□ □+ 86□ 13559599186



□□□□□ boreway05@boreway.net



□□□